



**Missoula City Public Works  
Standards and Specifications Manual**

**CHAPTER 4 – WATER SYSTEM**

**November 18, 2020**

# CHAPTER 4 – WATER SYSTEM

## Table of Contents

<b>4.1</b>	<b>Introduction .....</b>	<b>4-1</b>
4.1.1	References .....	4-1
4.1.2	Appendices .....	4-1
4.1.3	Standard Modifications to MPWSS.....	4-1
4.1.4	Standard Drawings.....	4-1
<b>4.2</b>	<b>General Requirements .....</b>	<b>4-1</b>
4.2.1	Design Standards .....	4-2
4.2.2	Plan Requirements.....	4-2
4.2.3	Design Report .....	4-3
4.2.4	General Water Service Requirements .....	4-4
4.2.5	Wet Utility Main Best Practices .....	4-5
4.2.6	Public Infrastructure Review Stage Process .....	4-6
4.2.7	Utility Service Area.....	4-6
4.2.8	Latecomer’s Agreement and Payment for General Benefit Facilities .....	4-6
4.2.9	Upsizing.....	4-6
4.2.10	Tie-ins to Existing System .....	4-6
4.2.11	Construction Documentation .....	4-7
4.2.12	Temporary Water .....	4-7
4.2.13	Abandonment or Reuse of Existing Water Service Lines.....	4-7
4.2.14	Requirements for Taps to Be Performed by Missoula Water.....	4-8
4.2.15	Requirements for Working Around Existing Mains and Services .....	4-8
<b>4.3</b>	<b>Design Standards .....</b>	<b>4-9</b>
4.3.1	Water Mains .....	4-9
4.3.2	Fittings and Bends.....	4-14
4.3.3	Valves.....	4-15
4.3.4	Fire Hydrants.....	4-15
4.3.5	Blow-Offs .....	4-17
	Table 4-1 – Blow-Off Size Required to Achieve Minimum Flushing Requirements.....	4-17
4.3.6	Manual Air-Relief Valves.....	4-17
4.3.7	Service Taps .....	4-17
	Table 4-2 – Approved Tapping Saddles.....	4-18
4.3.8	Water Service Lines .....	4-19

4.3.9	Curb Stops.....	4-20
4.3.10	Meter Pits .....	4-20
4.3.11	Cross-Connection/Backflow.....	4-21
4.3.12	Disinfection and Bacteriological Testing.....	4-21
	Table 4-3 - Quantity of Calcium Hypochlorite Required for Disinfection .....	4-23
	Table 4-4 – Required Flow and Openings to Flush Pipelines with 40 PSI Residual in Main .....	4-24
	Figure 4-1 – Suggested Combination Blow-off and Sampling Tap.....	4-25
	Table 4-5 - Chlorine at 1% Concentration Required to Produce 25 mg/L Concentration .....	4-25

## CHAPTER 4 - WATER SYSTEM

### 4.1 Introduction

#### 4.1.1 References

- A. *Montana Public Works Standard Specifications* (MPWSS), 6<sup>th</sup> Edition, 2010 – by purchase only
- B. American Water Works Association (AWWA) / ANSI Standards – by purchase only
- C. [Montana Department of Environmental Quality Circular-1: Standards for Water Works \(DEQ-1\)](#)
- D. [2018 Uniform Plumbing Code \(UPC\)](#)
- E. [City of Missoula 2018 Water System Master Plan](#)
- F. [Frequently Asked Questions about Water & Sewer for Accessory Structures](#)

#### 4.1.2 Appendices

- A. [Appendix 4-A – Cross Connection Backflow Program](#)
- B. [Appendix 4-B – Water Ditch Card Template](#)
- C. [Appendix 4-C – Allowable Non-Storm Water Discharges](#)

#### 4.1.3 Standard Modifications to MPWSS

- A. Specifications not specifically contained herein related to water improvements shall be in conformance with the *Montana Public Works Standard Specifications* (MPWSS), 6<sup>th</sup> Edition, 2010 and the following City of Missoula Modifications to the MPWSS, which are located in [Appendix 2-A](#):
- B. SECTION 01400 Contractor Quality Control and Owner Quality Assurance
- C. SECTION 02221 Trench Excavation and Backfill for Pipelines and Appurtenant Structures
- D. SECTION 02660 Water Distribution
- E. SECTION 02740 Pipe Casings and Appurtenances

#### 4.1.4 Standard Drawings

Standard drawings related to water system improvements shall be in conformance with the Montana Public Works Standard Specifications (MPWSS), 6<sup>th</sup> Edition, 2010 Standard Drawings and the 400-series of the City of Missoula Standard Drawings on the [Missoula City Public Works Standards and Specifications Manual](#) web page.

### 4.2 General Requirements

- A. The contractor or developer must contact Missoula Water during the subdivision or building permit process to determine whether there is a water main adjacent to the property. If there is no water main adjacent to the property, Missoula Water must determine whether a main extension will be required. If a main is required, it must be designed in accordance with this Manual and submitted under the City of Missoula [Public Infrastructure Review Stage Process](#).
- B. The specifications contained herein are the latest adopted specifications by Missoula Water. The specifications are to be used in conjunction with Montana Department of Environmental Quality

(DEQ) and American Water Works Association (AWWA) standards for the design and installation of water works facilities.

- C. The specifications and detail drawings shall be made a part of the improvement plans, contract documents, and project manuals for construction of water mains and/ or other appurtenances.
- D. Any reference to an AWWA standard contained within this Manual implies the latest edition of the standard.
- E. All contract documents must be completed and signed prior to the beginning of construction.

#### **4.2.1 Design Standards**

- A. Water systems shall be designed, constructed, and tested in accordance with the current edition of Circular DEQ-1 – Montana Department of Environmental Quality – Standards for Water Works and the *Montana Public Works Standard Specifications* with the most current City of Missoula Standard Modifications, the Missoula Water Standard Drawings, and these standards.
- B. The purpose of these standards is to establish the minimum requirements for the design and construction of municipal water facilities.

#### **4.2.2 Plan Requirements**

- A. Water system improvement plans shall comply with the specific requirements of [Chapter 1 of Circular DEQ-1](#) and [Section 3.2](#) of this Manual and include:
  - 1. Location, size and materials of existing and proposed water mains.
  - 2. Location, size and depth of other utilities in the vicinity of the proposed improvements, including sanitary sewers, storm drains, dry wells, gas facilities, and dry utilities. This shall include both mainlines and customer-owned service lines.
  - 3. Location of existing and proposed boulevard or street trees. Existing trees should be drawn to show the approximate measured drip line.
  - 4. Dimensions between water mains and nearby sources of contamination (dry wells, sanitary sewers, etc.). These are particularly important where the separation distance is at or close to the minimum distances required in DEQ-1.
  - 5. Where deviations will be required from DEQ-1 separation requirements, provide a detailed description of protective measures which will be employed to support the deviation request.
  - 6. Detailed descriptions for all appurtenances to be installed, including stations, appurtenance name (e.g., 8-inch gate valve), connection types (mechanical joint, flanges, etc.), and related appurtenances (valve box, thrust block, etc.).
  - 7. The length of the hydrant lead pipe.
- B. The plans shall specify the bury depth of the hydrant based on the finish ground elevation at the hydrant bury line. Hydrant extensions are not allowed, so it is the responsibility of the engineer to call out an accurate bury depth for the hydrant assembly.
- C. Profiles shall identify estimated depth of all utility crossings.

### 4.2.3 Design Report

- A.** All water main extensions and replacements shall require the engineer of record to submit a written, stamped report to the City addressing the fire, irrigation and domestic flow requirements. The engineering report shall meet all requirements of DEQ-1 Section 1.1 in addition to the requirements below.
- B. Water Demands.** Include estimated water demands based on projected land use, occupancy, and building type. The design engineer shall provide all relevant references, assumptions and calculations for alternate methods of non-residential water demand estimation within the submitted report. Maximum day and peak hour peaking factors shall be included. Water demands shall be provided for the following conditions:
1. Average Daily Demand (GPM/connection)
    - a. The *City of Missoula 2018 Water System Master Plan* Table 3-19 recommended an average demand per single family residential connection of 140 gallons/capita/day and 2.3 people/single family residence. Based on that, residential projects can assume a demand of 0.22 gpm/single family residence.
    - b. The *City of Missoula 2018 Water System Master Plan* Table 3-19 recommended an average demand per employee of 63 gallons/capita/day. Average commercial demands can be estimated based on that average demand times the anticipated number of employees.
  2. Maximum Daily Demand (GPM/connection). Maximum day multipliers can be based on *City of Missoula 2018 Water System Master Plan* Figure 3-16.
  3. Peak Hourly Demand (GPM). Peak hour multipliers can be based on *City of Missoula 2018 Water System Master Plan* Figure 3-16.
  4. Required Fire Flow (GPM) and Duration (hours)
  5. Irrigation Flow (GPM) for parks.
- C. System Layout.** Describe and show the proposed distribution system layout, including locations for connections with the existing water distribution system. Hydrant locations and fire flow requirements shall also be approved by the City Fire Marshall.
- D. Conformance with Master Plan.** Describe how the proposed water system improvements conform with the current [City of Missoula 2018 Water System Master Plan](#).
- E. Hydraulic Model.** The City of Missoula typically performs a distribution system analysis, performed through hydraulic modeling with input from the design consultant, identifying any system impacts based on proposed demands and provide design solutions to ensure future water system growth, while maintaining appropriate system pressures and flow rates.
- F. Sizing.** Indicate the required sizing of the proposed distribution mains based on water demands.
- G. Allowable Pressures.** The City of Missoula requires a minimum normal working pressure of 45 psi and a maximum working pressure of 100 psi. Pressures outside this range needs to be approved in writing by the City. The City prefers operating pressures in the range of 60-80 psi.
- H. Other.** Identify any special conditions, such as the presence of contaminated soils, conflicts with other utilities, unusual installation depths, or any requirements that require special provisions for construction.

#### **4.2.4 General Water Service Requirements**

- A.** Service lines shall be installed perpendicular to the main unless otherwise approved by the City Engineer. Applicants wishing to install services parallel to the right of way must submit a Services-in-Right-of-Way Request, which is included in [Appendix 2-C](#) of this Manual.
- B.** All water mains and service lines should generally be installed 10-ft from curbs, sidewalks, storm drain inlets and pipes. There are more specific separation requirements for water mains in Section 4.3 of this chapter.
- C.** Specific information for water service for accessory structures on a property can be found at [Frequently Asked Questions about Water & Sewer for Accessory Structures](#).
- D.** For properties requiring a fire line, there should be separate connections to the main and separate shutoff valves for the fire line and domestic line.
- E.** All new services shall be metered.
- F.** All meters shall be Neptune™ meters and can be obtained at Missoula Water.
- G.** Curb boxes shall be placed in a boulevard or immediately behind curb side sidewalk. These should be installed at least 10-ft laterally from any existing tree.
- H.** All new residential meters (up to and including tri-plexes) shall be installed in a meter pit located on private property not more than 5 feet outside the right-of-way line or dry utility easement (if present) as shown in City of Missoula Standard Drawing 404.
- I.** Meter pits and curb boxes shall not be located where vehicles are expected.
- J.** All new commercial and multi-family meters (4-plex and greater) shall be installed in a mechanical room as shown in City of Missoula Standard Drawing 403. Any exceptions to this requirement must be approved in writing by Missoula Water.
- K.** Commercial services, irrigation services, and any service with a fire line or auxiliary water source (irrigation well, ditch, etc.) shall require backflow protection as described in [Appendix 4-A](#). In most instances, commercial and fire services require reduced pressure principle backflow prevention assemblies.
- L.** Irrigation for commercial service lines should be metered separately to avoid sewer charges on the irrigation volumes. Irrigation meters are allowed to be installed either in a mechanical room or in a meter pit as shown in City of Missoula Standard Drawing 412.
- M.** Meters 1 ½ -inch and larger (except irrigation meters) require a bypass as shown in City of Missoula Standard Drawing 403.
- N.** Customers should consider individually metering food service components due to the difference in sewer billing rates for food service and general commercial uses.
- O.** A separate shutoff valve accessible outside the building is required for each metered account.
- P.** Connections to public water outside the city limits shall comply with the requirements established in [City of Missoula Resolution 8181](#).
- Q.** All meters that are installed inside a building or inside a pit with a metallic lid shall have a transmitter installed remotely on an exterior building wall. A ½” PVC conduit shall be installed from the meter to the transmitter.

#### **4.2.5 Wet Utility Main Best Practices**

The term “wet utility main” refers to water, sanitary sewer or storm water mains where applicable. These rules must be followed when designing wet utility mains. When the design engineer feels it is not practical to follow these rules, they must request a deviation to the rules with a written description as to why it is not practical to follow the rules. City staff will make a determination as to whether the deviation will be accepted or denied.

- A.** All parcels desiring water or sewer service shall have a water and sanitary sewer main fronting a property line.

Exception: The public works department may consider a deviation for a single family residential project if it determines that there is no reason to further extend the main in the future. The applicant needs to fill out the “Request for Permission to Install Private Utility Service in Public Right-of-Way” form and submit it to Development Services.

- B.** Wet utility mains should be installed all the way across all parcels being served. Latecomer agreements can be created to collect proportional costs from other properties connecting service lines to the main.

Exception: Wet utility mains may be allowed to terminate at the midpoint of the last parcel being served if new asphalt, hardscape, or landscaping are not planned to be installed with the development beyond the midpoint of the parcel. If mains are not required to be extended all the way across the last parcel, easements or right-of-way must be provided such that the main could be extended in the future.

- C.** Water and sanitary sewer mains should be extended such that each structure can be served with water and sanitary sewer services perpendicular to the main.

Exception: Water service lines and sanitary sewer service lines for adjacent residential parcels will be allowed in shared trenches provided that reciprocal easements are created near the shared property corner that will allow for future repair/replacement of the lines. This exception does not exempt the applicant from complying with subsection B above.

- D.** Wet utility main alignments should parallel the street right-of-way to maximize right-of-way available for future utilities. Additional sanitary sewer and storm water manholes will likely be required on curves.
- E.** Sanitary sewer and storm water mains should be situated such that manholes are installed in the centerline of the road or in the center of a driving lane.
- F.** Street trees shall not be installed within 10 feet of wet utility mains, as measured from center of tree to center of pipe.
- G.** Wet utility mains should be installed within the asphalt section of the road or alley prism.
- H.** Wet utility mains should not be installed under curbs and sidewalks.
- I.** No sewer main shall be within 3 feet of the nearest point of any storm manhole, catch basin or dry well. The sump rock is considered to be a part of a dry well.
- J.** No water main shall be within 5 feet of the nearest point of any sanitary or storm manhole or dry well. The sump rock is considered to be a part of a dry well. Water mains closer than 10 feet from a dry well will require a deviation from DEQ.



#### **4.2.6 Public Infrastructure Review Stage Process**

Water projects shall follow the City of Missoula [Public Infrastructure Review Stage Process](#).

#### **4.2.7 Utility Service Area**

The utility service area map is available on the City website and through this [link](#).

#### **4.2.8 Latecomer's Agreement and Payment for General Benefit Facilities**

Latecomer's fees are described in Chapter 2 of this Manual.

#### **4.2.9 Upsizing**

Missoula Water may require larger water mains than the minimum main sizes required for a particular development, in order to serve other developments in the area. In those instances, Missoula Water will pay the construction cost of the upsize difference between the main size to be installed and the minimum main size required for the development.

#### **4.2.10 Tie-ins to Existing System**

- A.** It is imperative that all connections to Missoula Water's existing system be performed in an efficient and timely manner with minimal interruption to existing customers. All tie-ins to the existing system shall be overseen by Missoula Water personnel.
- B. Operation of Existing Facilities.** All operation of existing system valves shall be performed by Missoula Water employees unless otherwise previously arranged.
- C. Taps into Existing System.** All taps necessary to tie-in to Missoula Water's existing system will be performed by Missoula Water personnel unless otherwise previously arranged. Missoula Water will charge the Contractor a tapping fee for each service or mainline tap on a Missoula Water main and Missoula Water will provide the tapping saddle or sleeve. Missoula Water will also provide corporation stops for taps 2 inches and smaller. The contractor shall provide valves for all taps larger than 2 inches. No tapping fee will be charged for new main connections that will involve cutting in a new tee and the contractor will be required to provide the tee and all other appurtenances. The contractor is responsible for providing a job site that meets all local, state, and federal laws, statutes, and regulations. A properly sloped trench or a trench box with adequate room to complete the tap is required.
- D. Cathodic Protection.** Cathodic protection shall be provided using 32-pound magnesium anodes cad-welded to the main anytime an existing steel main is exposed. Unless otherwise noted, a single anode jumpered across a new connection is sufficient for tie-ins to existing mains.
- E. Notification.** A minimum of 24 hours' notice for residential customers and 48 hours for commercial customers shall be required prior to any disruption of water service except in emergency circumstances. Notification of customers shall be coordinated with Missoula Water personnel.
- F. Pipe Materials Containing Asbestos.** All activities involving asbestos cement pipe, related fixtures containing asbestos pipe materials, and steel pipe with wraps potentially containing asbestos shall be performed in accordance with all Local, State, and Federal regulations. A licensed, bonded and accredited in Montana asbestos abatement contractor shall be used to perform the required work including the transport and disposal of any asbestos-containing waste materials.

#### **4.2.11 Construction Documentation**

- A. As-Built Drawings.** The engineer of record is required by the DEQ approval to certify that the project is completed in substantial accordance with approved plans. The engineer is also required to submit a complete set of as-built drawings to the DEQ. In order to complete these tasks, the engineer is required to inspect construction of the facilities and to keep detailed notes in daily logs.
- B. Construction Photographs.** At a minimum, construction photos shall be taken at all fittings and valves. Photos shall be taken before the fitting is wrapped to create a record of the connections and after the tie downs and thrust blocks are in place for future reference as to size and construction. Additional photos shall be taken as necessary to document construction. Photos shall be clearly annotated for future identification of location and orientation using a whiteboard, noting the date, station and items pictured.
- C. Ditch Cards.** The contractor shall be required to complete a ditch card for each new, repaired, or replaced water service connection using the template included in [Appendix 4-B](#).
- D.** Detailed requirements for construction documentation submittal is contained in Stage 6 of the [Public Infrastructure Review Stage Process](#).

#### **4.2.12 Temporary Water**

- A.** Under no circumstances shall temporary water be provided to a customer through another customer's connection, a fire hydrant, or other means unless specifically approved by Missoula Water personnel.
- B.** Should a temporary water system be necessary for construction or other purposes, it shall be tapped directly to an existing Missoula Water main, equipped with backflow, disinfected, tested for bacteriologic contaminants in accordance with this Manual, and pressure tested as approved by Missoula Water Quality personnel and in accordance with all applicable DEQ standards including DEQ 1, Section 8.15, Temporary Water Distribution.
- C.** No such systems shall be provided without prior approval by the City Utility Engineer.
- D.** Hydrants may be utilized as a source of temporary water provided they are also disinfected and tested for bacteriologic contaminants.

#### **4.2.13 Abandonment or Reuse of Existing Water Service Lines**

- A.** It shall be the responsibility of the owner of the new service line to abandon the old service at the main.
- B.** Failure to abandon service lines not in use may result in termination of water service to the property.
- C.** A service line that is to be abandoned shall be excavated at the tap on the water main, the corporation stop shut off, and the service line cut and capped at the corporation. The packing nut must also be tightened.
- D.** Abandonment must be inspected by a Missoula Water employee.
- E.** Any visible leak at the corporation shall be repaired prior to backfill.
- F.** If a service is abandoned by hydro-excavation methods, it is acceptable not to cap the service line after it is cut off.

- G. Any existing service line that an applicant wishes to reuse, that was installed prior to the year 2000, shall be required to be pressure tested before any permits will be issued for its reuse. Pressure testing of any line 2 inches and smaller requires that the line be excavated at the main and the corporation stop closed during the test.

#### **4.2.14 Requirements for Taps to Be Performed by Missoula Water**

- A. Missoula Water personnel are required to make all taps on existing water mains. The following requirements must be met before Missoula Water personnel will perform the tap:
  - 1. Traffic control must meet statutory requirements and have been approved by City Engineering.
  - 2. Appropriate trench protective system (trench box, shielding or sloping) that is adequate for the job, with a minimum width 4 feet as shown in [City of Missoula Standard Drawing 401](#).
  - 3. Trench box must have approved end panels.
  - 4. Trench box must have an engineering document that the trench box has been certified.
  - 5. Trench must have an approved ladder that extends 3 feet above the trench box and ditch bank and meets OSHA requirements.
  - 6. Trench box cannot be placed on the water main or other utility pipes.
  - 7. A ramp must be provided if there will be more than 12 inches between the trench box and ditch bank.
  - 8. There shall be no equipment running adjacent to an open trench on job site while the tap is being done.
  - 9. All materials must be at the job site including pipe bedding for the Missoula Water pipe.
- B. For projects with multiple taps, the required distance between taps must be 12 inches on ductile iron and 18 inches on steel and PVC mains.

#### **4.2.15 Requirements for Working Around Existing Mains and Services**

##### **A. Water Mains**

- 1. Any construction work causing disturbance of backfill materials beneath cast iron or asbestos cement (AC) water mains shall be backfilled up to the bottom of the water main with flowable fill in accordance with MPWSS Section 02225.
- 2. Any construction work causing steel water mains to be exposed shall require installation of sacrificial anodes on the steel mains. Missoula Water will provide the anodes and will perform the cad welding to install the anodes at the request of the contractor. The Contractor shall provide 48 hours' notice prior to the time the anodes will need to be installed. The contractor shall provide all required safety devices prior to Missoula Water personnel entering a trench.
- 3. Only Missoula Water personnel are allowed to operate water main valves.
- 4. Valve boxes shall be left flush with the street surface final grade.
- 5. Imported pipe bedding shall be placed around any portion of a water main exposed in accordance with [City of Missoula Modification to MPWSS Section 02221](#).
- 6. Only Missoula Water approved contractors are allowed to make repairs to Missoula Water owned facilities.

7. The contractor shall protect and/or replace tracer wire along mains.
8. Any water valves covered or paved over should be uncovered within 24 hours.

#### **B. Water Services**

1. Notice shall be provided with an appropriate door hanger tag a minimum of 24 hours prior to a shutdown of a residential water service and 48 hours prior to a shutdown of a commercial water service.
2. Property owners own their water service from the corporation stop at the water main to the house, with the exception of the meter. Thus, repairs or modifications to water services shall be performed as directed by the property owner in accordance with Missoula Water specifications for service line installations.
3. All fittings and appurtenances to be buried shall be designed for direct burial applications (e.g., ball valves).
4. Any repaired services lines shallower than 6 feet shall be insulated sufficiently with blue board insulation to protect against freezing.
5. If galvanized service pipe is repaired with polyethylene pipe, electrical continuity of the galvanized pipe shall be maintained by connecting #14 tracer wire to the galvanized pipe on both sides of the repair using LH Dottie DB25 bare ground clamps or equivalent direct bury-rated ground clamps.
6. The contractor shall make every effort to minimize contamination of water service lines and prevent foreign material from entering the pipe. Where there is concern of contamination from sanitary or storm sewer systems, all materials installed in the service lines shall be disinfected with bleach solution.
7. Water service line repairs shall be performed in accordance with all applicable City of Missoula requirements.
8. Contractor shall provide Missoula Water with updated ditch card information any time a service line or curb box is disturbed or relocated. The ditch card form located in Appendix 3-E should be completed for each service line with all available information.

### **4.3 Design Standards**

#### **4.3.1 Water Mains**

##### **A. Sizing and Location**

1. Main sizes shall be determined based on the results of hydraulic modeling performed by Missoula Water.
2. Mains in residential areas shall be minimum 8-inch diameter and mains in commercial and multifamily areas shall be minimum 12-inch diameter unless otherwise approved.

##### **B. Products**

1. Materials shall be new and supplied by the contractor unless otherwise arranged. Materials used in the installation or repair of the water system shall be lead free (not more than 0.25% lead).

2. Pipe shall be Class 350 Ductile Iron Pipe in accordance with AWWA C150 and C-151, unless otherwise approved by City Utility Engineer. The interior of the pipe shall be cement mortar lined in accordance with AWWA C104. The outside coating shall be bituminous coating in accordance with AWWA C151. All Ductile Iron Pipe shall be encased in 8 mil polyethylene wrap in accordance with AWWA C105 and manufacturer's recommendations. The polyethylene encasement shall prevent contact between the pipe and the surrounding backfill and bedding material, but it is not intended to be a completely airtight or watertight enclosure.
3. Joints may be either rubber ring gasket push-on or mechanical in accordance with AWWA C111. Fittings shall be in accordance with AWWA C110. Fittings shall be coated and encased the same as the pipe. Joints for fittings shall be the same as the pipe.
4. For boring projects, DR11 HDPE pipe with DIPS dimensions manufactured to the requirements of ASTM F714 and AWWA C906-15 will be allowed. The engineer of record will be required to submit a detailed specification for the project, which shall include a requirement that the persons performing heat fusion have a current certification within the last two years from a training provider that meets ASTM F3190 and follows the guidelines in ASTM F2620. HDPE pipe must be one size larger than adjacent ductile iron mains.
5. If insulation is required due to shallow bury depth or close proximity to sanitary sewers, manholes, storm inlets, or storm drains, the thickness and type of insulation shall be identified on the plans by the engineer of record. The specified insulation shall have a compressive strength of no less than 35 psi if installed in traffic areas.
6. Buried warning tape and tracer tire shall be installed in all water main and service line trenches. Warning tape shall be 3 inches wide, blue, marked "Caution Water Line Buried Below".
7. Tracer wire shall be at a minimum #14 solid copper direct bury wire and shall be blue color. Where new water service line transitions to existing galvanized service line, the new tracer wire should be attached to the galvanized pipe using a Christy's or approved equal UL approved bronze grounding clamp suitable for direct burial.

### **C. Installation**

1. Installation shall be in accordance with AWWA C600. Bury depth should typically be less than 7.5 feet from finished grade to top of pipe, except where otherwise indicated on the plans. All water lines shall be buried a minimum depth of six feet unless otherwise approved by the City Utility Engineer. Insulation will be required in order for Missoula Water to approve a shallower bury depth. The plans should call out the required thickness of insulation, but at a minimum there should be a 1-inch thickness of insulation for each foot of cover less than 6 feet. Where multiple layers of insulation are to be provided, the engineer of record must include a detail showing the layers taped together with staggered joints.
2. Where water and sewer mains or services must cross and cannot main vertical separation requirements specified in this chapter, both shall be installed in accordance with [City of Missoula Standard Drawing 402](#). Measures shall be taken during installation to prevent the entrance of contaminants into the water lines. Lumps of clay, mud, cinders, etc., on the pipe

surface shall be removed prior to installation of the polyethylene wrap. During installation, soil or embedment material shall not be trapped between the pipe and the polyethylene. Cuts, tears, punctures, or other damage to the polyethylene shall be repaired with adhesive tape or with a short length of polyethylene wrapped around the pipe to cover the damaged area and secured in place in accordance with AWWA C105.

3. Buried warning tape shall be placed directly over the pipeline 18 inches below the finished surface. Warning tape shall not be required for any lines that are tunneled or pushed beneath roadways.
4. Tracer wire shall be taped to the top center of the pipeline prior to backfilling. Tracer wire connections will be made by twisting the wires, installing a silicone-filled water resistant wire nut, and wrapping the connection with electrical tape. Tracer wire shall be brought to the surface at each valve or other appurtenance that is at the ground surface. Small diameter PVC conduit shall be used in valve boxes to house the tracer wire brought to the surface.
5. Water mains may be required to be installed through a casing by City Engineering or the jurisdictional authority (i.e., railroad, Interstate (MDT), etc.). Casing requirements shall conform with [City of Missoula Modification to MPWSS Section 02740](#), or jurisdictional standards.
6. Trench, bedding, and backfill shall be in conformance with [City of Missoula Modification to MPWSS Section 02221](#) and [City of Missoula Modification to MPWSS Section 01400](#).

#### **D. Testing**

1. Water mains and appurtenances shall be disinfected and tested for bacteria in accordance with Section 4.3.12 of this chapter. Following completion of those procedures, water mains and services to the curb box shall be pressure tested as described in this section.
2. No hydrostatic pressure test will be made against any portion of the system until satisfactory bacteriological sample reports are received. All bacteriological test results for the section of line to be statically tested must be in possession of the engineer of record prior to beginning the test. The test must be observed, recorded, and certified by either the engineer of record or a representative of Missoula Water. The pressure test apparatus must be inspected by the engineer of record or a representative of Missoula Water prior to the start of the test.
3. All pressure testing shall be in accordance with AWWA Standard C600.
4. After the pipe has been laid and bacteria testing successfully completed, all newly laid pipe or any valved section of pipe shall be subjected to a hydrostatic pressure of not less than 1.5 times the stated working pressure at the lowest elevation of the test section. The pressure test shall be at least 2 hours in duration.
5. Pressure testing of all newly laid pipe shall include service lines up to the curb box. The contractor may choose to pressure test the main line prior to connecting the service lines. In this case, a subsequent pressure test will be required to include the service lines up to the curb box.

6. All equipment used in pressure testing shall be intended for use in potable water systems and should only be used for pressure testing potable water systems. All equipment shall be disinfected prior to conducting pressure tests.
7. Test pressures shall not:
  - a. Exceed the thrust restraint design pressures or 1.5 times the pressure rating of the pipe or joint, whichever is less,
  - b. Vary by more than +/- 5 psi,
  - c. Exceed the rated working pressure of the valves or hydrants when the pressure boundary of the test section includes closed, resilient-seated gate valves, butterfly valves, or hydrants, and
  - d. Be less than 1.5 times the stated working pressure at any time during the test. If the test pressure drops below 1.5 times the stated working pressure, the test shall be terminated and re-started at a higher pressure.
8. Each valved section of pipe shall be filled with water slowly and the specified test pressure, based on the elevation of the lowest point of the line or section under test and corrected to the elevation of the test gauge, shall be applied by means of a pump connected to the pipe in a manner satisfactory to Missoula Water personnel.
9. Before applying the specified test pressure, air shall be expelled completely from the pipe, valves, and hydrants. If permanent air vents are not located at all high points, the contractor shall install corporation cocks at such points so that the air can be expelled as the line is filled with water. After all air has been expelled, the corporation cocks shall be closed and the test pressure applied. At the conclusion of the pressure test, the corporation cocks shall be removed and plugged, or left in place at the discretion of Missoula Water personnel.
10. Exposed pipe, fittings, valves, hydrants, and joints shall be examined carefully during the test. Any damaged or defective pipe, fittings, valves, or hydrants that are discovered following the pressure test shall be repaired or replaced with sound material and the test shall be repeated until it is satisfactory to Missoula Water personnel.
11. Determination of acceptable leakage rate shall be performed as follows:
  - a. Leakage shall be defined as the quantity of water that must be supplied into the newly laid pipe, or any valved section thereof, to maintain pressure within 5 psi of the specified test pressure after the air in the pipeline has been expelled and the pipe has been filled with water.
  - b. Allowable leakage. No pipe installation will be accepted if the leakage is greater than that determined by the following formula:

$$L = \frac{S \times D \times \sqrt{P}}{148,000}$$

in which L is the allowable leakage, in gallons per hour; S is the length of the pipeline tested, in feet; D is the nominal diameter of the pipe, in inches; and P is the average test pressure during the leakage test in pounds per square inch.

12. When testing against closed metal seated valves, an additional leakage per closed valve of 0.0078 gallon/hour/inch of nominal valve size shall be allowed.
13. When hydrants are in the test section, the test shall be made against the closed hydrant.
14. Acceptance shall be determined on the basis of allowable leakage. If any test of pipe laid discloses leakage greater than that specified in G.2 of this section, the contractor shall, at their own expense, locate and repair the defective material until the leakage is within the specified allowance.
15. All visible leaks must be repaired regardless of the amount of leakage.

**E. Separation of Water Mains and Sanitary or Storm Sewer Facilities**

1. **Horizontal Separation between water and sewer mains.** Where water mains and sanitary or storm sewer mains are shown to run parallel on the plans they shall be separated by a minimum horizontal distance of ten feet as measured from the edges of the pipe (outside wall of the mains). Water mains shall also be separated a minimum of 10 feet from the edge of storm drain sumps. If the minimum separation cannot be maintained, a deviation request must be approved by DEQ. All installations must be performed in accordance with the conditions set forth in the deviation approval.
2. **Horizontal separation between water mains and sumps.** Sumps shall not be installed within 10 feet from a water main, measured between the outer walls of the water main and sump barrel. If that separation cannot be maintained, the water main shall be protected with flowable fill and/or insulation as described below.
  - a. If the installation involves installing or exposing the water main, the water main should be encased in a minimum of 6 inches of flowable fill above and below the main, extending 10 feet along the water main in both directions from the location not meeting separation requirements. If the sump rock is less than 6 feet from the water main, a 4-foot x 8-foot sheet of insulation should also be installed vertically at the edge of the sump excavation nearest the water main. The long dimension of the insulation should be in the vertical direction.
  - b. If the installation does not involve the water main being installed or exposed, a 4-foot x 8-foot sheet of insulation should also be installed vertically at the edge of the sump excavation nearest the water main. The long dimension of the insulation should be in the vertical direction.
3. **Vertical Separation between water mains and sanitary or storm sewer mains.** Unless otherwise shown on the plans, water mains shall be adjusted in burial depth so as to cross over sanitary or storm sewer mains. The bottom of the water main shall be at least 18 inches above the top of the sewer main. Where burial depth is inadequate over water mains or where it is shown on the plans that the water main must pass below the sewer main, the vertical separation between the top of the water main and the bottom of the sewer main shall be at least 18 inches.
4. When water or sewer pipe is installed, lengths shall be centered at the point of crossing so as to maximize the distance that all pipe joints are from the crossing. No pipe joints shall be allowed at the point of crossing.



#### **F. Abandonment of Water Lines**

Where existing water lines are to be abandoned in place, contractor shall install a water tight cap or plug.

#### **G. Dead End Mains**

Water mains shall be looped where possible. Permanent dead end mains should be less than 500 feet long unless otherwise approved in writing by Missoula Water. All dead end mains shall terminate with a blowoff sized in accordance with Section 4.3.5 of this chapter or with a fire hydrant. Automatic flushing devices may be required on long dead ends.

#### **H. Main Stubs for Future Extension**

1. Water main stubs intended for future extension should include a valve that will allow the new main to be installed without draining mains serving customers. The stub should also include a blowoff on the end a minimum of 18 feet from the valve and no services shall be installed between the valve and blowoff. If the isolation valve is not flanged to a tee or cross, the valve should be thrust blocked as described in Section 4.3.3 of this chapter, and there should be no unrestrained joints within 36 feet of the blowoff.
2. Piping connections shall be made in all streets where feasible and main extensions shall be stubbed out in all streets to the property line for future extensions. No blind flanges or caps are allowed on tees and blowoffs on stubs shall be at least 5 feet from tees.

### **4.3.2 Fittings and Bends**

#### **A. Products**

1. All flanged fittings shall be ductile iron rated for 250 psi working pressure and meeting the requirements of AWWA C110. Mechanical joint fittings shall be ductile iron rated for 350 psi working pressure and meeting the requirements of AWWA C153.
2. All flanged fittings shall utilize Full Face Flange TYTE Gaskets™ or approved equal.

#### **B. Installation**

1. Deflections at fittings and couplings shall not exceed 60% of the pipe manufacturer's recommendations.
2. Thrust restraint shall be required at all changes in direction such as tees and bends (greater than 11.25°), changes in size (at reducers), stops and dead ends.
3. Thrust restraint shall consist of restrained joints and thrust blocking at all fittings unless otherwise specified in [City of Missoula Standard Drawing 407](#).
4. Thrust blocking shall be in accordance with design criteria contained herein and in accordance with other approved pipe manufacturer's recommendations.
5. Concrete thrust blocks in accordance with MPWSS Section 03310 shall be used unless otherwise specified.
6. Steel tie backs and welds must be in accordance with pipe manufacturer's recommendations and approved by the engineer of record.
7. All thrust restraint must be approved by the engineer of record prior to backfilling.
8. All bolts shall be torqued according to the manufacturer's specifications.

### 4.3.3 Valves

#### A. Products

1. Valves shall be flanged, mechanical joint, or a combination thereof as specified for the particular application.
2. Gate valves shall be used for applications 10 inches and smaller. Valves shall be rated for 350 psig maximum working pressure. Mueller or AVK Resilient Wedge gate valve or approved equal shall be used and shall meet or exceed AWWA C509.
3. Butterfly valves shall be used for applications 12 inches and larger. Missoula Water will consider deviations to allow 12 gate valves to be used instead if the engineer submits a request in writing with appropriate justification. Valves shall be rated for 250 psig maximum working pressure. Mueller Lineal XPII, AVK, or approved equal butterfly valves shall be used and shall meet or exceed AWWA C504.
4. Valve boxes shall be cast iron, adjustable stem, marked with word "WATER" on lid. All valve boxes shall be 3-piece, screw type with 5-1/4-inch shaft compatible with the valve and shall not rest on the pipe. All boxes shall be set plumb and to the finish grade of surrounding material.
5. All flanged valves shall utilize Full Face Flange TYTE Gaskets™ or approved equal.

#### B. Installation

1. Valve spacing shall be a maximum of 800 feet and at the end of each block in residential areas and 500 feet in commercial and industrial areas.
2. Valves shall also be placed near the end of mains planned for extension in the near future (i.e., at phase boundaries in multi-phased developments), such that no customers are out of water when the main is extended.
3. All valves 4 inches and greater shall be tied down in accordance with [City of Missoula Standard Drawing 406](#) unless they are flanged to a tee or cross connected to branch piping in at least two directions. Each piping branch must be at least 18 feet from the tee or cross to the first unrestrained joint.
4. All valves shall be installed in accordance with the manufacturer's recommendations and as shown in the [City of Missoula Standard Drawings 405](#) and [406](#).
5. All bolts shall be torqued according to the manufacturer's specifications.

### 4.3.4 Fire Hydrants

#### A. Products

1. **Fire Hydrant Assembly.** Fire hydrants shall be Mueller Super-Centurion or newer, AVK, or approved equal meeting all requirements of AWWA Standard C502 and as follows:
  - a. Valve opening shall be minimum 5-1/4 inches.
  - b. Hydrant shall be three-way with two 2-1/2-inch hose nozzles (National Standard Thread) and one 4-1/2-inch pumper nozzle (National Standard Thread).
  - c. Pumper nozzle shall be equipped with a Storz adapter as shown in City of Missoula Standard Drawings 420.
  - d. Hydrants shall have 1-1/2-inch pentagon operating nut, opening left.

- e. Flanged or mechanical joint inlet connection shall be 6 inches diameter or greater.
  - f. The hydrant shall be of the breakaway type so that in case of barrel breakage, the main valve will remain closed.
  - g. Fire hydrants shall be painted yellow.
  - h. The hydrant assembly shall be rated for working pressure 250 psig.
  - i. Hydrant bury depths should be called out on plan and profile drawings by the engineer of record.
2. Fire Hydrant Valve
    - a. Gate valves with approved manufactured boxes shall be in accordance with Section 4.3.3 of this chapter.
  3. Fire Hydrant Lead Pipe
    - a. Lead pipe shall be Class 350 Ductile Iron Pipe meeting all pertinent provisions of Section 4.3.1 of this chapter.
    - b. Electrical continuity shall be maintained from the water main to the hydrant with tracer wire in accordance with [City of Missoula Modification to MPWSS Section 02221](#).
    - c. Tracer wire shall be brought to the surface at the hydrant.
    - d. No unrestrained joints shall be allowed on a hydrant lead pipe.

## **B. Installation**

1. Fire hydrants shall be installed in accordance with the manufacturer's recommendations and as shown on City of Missoula Standard Drawings and in accordance with the current regulations of the City, County, or other Fire Department having jurisdiction.
2. The hydrant shall be positioned with the bury line on the hydrant set to finished grade with a minimum bury depth of 6 feet. The contractor is responsible for providing a hydrant of appropriate barrel length and installing the hydrant to final grade.
3. Bends may be used to get the fire hydrant to finished grade.
4. Hydrant extensions are to be avoided and will only be allowed with written permission of Missoula Water in the event the hydrant is installed below finished grade.
5. If allowed, Missoula Water personnel will install an extension as necessary at the cost of the contractor.
6. Fire hydrants shall be installed plumb.
7. Fire hydrants shall be located in the street right-of-way as shown on the plans unless otherwise specified.
8. No fire hydrant shall be set in a concrete sidewalk or concrete curbing unless specifically indicated on the project plans. Unless conditions otherwise dictate, hydrants shall be a minimum of 2 feet behind curb, sidewalk, or edge of asphalt.
9. Valves and boxes shall be installed in accordance with Section 4.3.3 of this chapter and shall be a minimum of 3 feet from the hydrant.
10. Lead pipe shall be installed in accordance with Section 4.3.1 of this chapter. Pipe shall be sized to assure minimum flow loss to the hydrant.

### 4.3.5 Blow-Offs

#### A. Products

1. Blow-off valves shall be Mueller A-2360 resilient wedge gate valve THD x THD with a 2-inch operating nut or approved equal. Valves shall meet or exceed AWWA C509.

#### B. Installation

1. Blow-offs shall be installed at the end of each dead end main to allow for proper flushing and maintenance both during and after installation.
2. Blow-offs shall be installed flush with finished grade in accessible locations that provide adequate drainage for flushing.
3. A minimum of 5 feet shall be maintained between the blow-off and other system appurtenances including, but not limited to, tees, valves and service taps.
4. A minimum of 5 feet shall also be maintained between blow-offs and any concrete curbs and sidewalks.
5. Blow-offs shall be sized as shown in Table 4-1 to achieve the minimum flushing requirements of 3 feet/second.

**Table 4-1 – Blow-Off Size Required to Achieve Minimum Flushing Requirements**

Pipe Diameter (inches)	Size of Blow-off (inches)*
8	3
10	3
12	3
14	4
16	4
20	6
24	6
30	8

\*Based on pressure of 80 psi in main

### 4.3.6 Manual Air-Relief Valves

#### A. Products

1. Manual air-relief valves shall be Mueller A-2360 resilient wedge gate valve THD x THD with a 2-inch operating nut or approved equal.

#### B. Installation

1. Manual air-relief valves shall be installed at all apparent high points along a newly installed water main and in any location during repairs or other activities where an apparent high point has been created.
2. Tap shall be made directly on top of the pipe for maximum air release.

### 4.3.7 Service Taps

#### A. Products

1. Tapping Saddles for Main Connections 2 inches or smaller

- a. All tapping saddles shall be C.C. thread, stainless steel, and meet the requirements in Table 4-2.

**Table 4-2 – Approved Tapping Saddles**

Pipe Type	Required Tapping Saddle (or approved equal)
OD Steel Pipe	ROMAC – 101NS Style SMITH BLAIR - 315
Ductile Iron Pipe	ROMAC – 101NS Style FORD – FC101 Style SMITH BLAIR - 315
PVC C900 Pipe	ROMAC – 202NS Style FORD – FC202 Style SMITH BLAIR - 397

**B. Tapping Sleeves for Main Connections larger than 2 inches**

Tapping sleeves shall be Romac SST stainless steel tapping sleeves or approved equal.

**C. Corporation Stops**

Corporation stops shall be Mueller 300 Series Ball Valves, Ford FB 400 Series, or approved equal with C.C. inlet and male I.P. outlet and shall be 1 inch minimum.

**D. Installation**

1. Before a tapping sleeve or saddle is installed, the exterior of the main to be tapped shall be thoroughly cleaned and the interior surface of the sleeve shall be sprayed with sodium hypochlorite solution.
2. Tapping sleeves are used to avoid shutting down the main to be tapped. After the tap is made, it is impossible to disinfect the annulus without shutting down the main and removing the sleeve. The space between a tapping sleeve and the tapped pipe is normally 1/2 inch, more or less, so that as little as 100 mg of calcium hypochlorite powder per square foot will provide a chlorine concentration of over 50 mg/L.
3. Where multiple taps are to be installed, the minimum distance required between taps is 12 inches on ductile iron mains and 18 inches on steel and PVC mains.
4. Multiple taps on PVC mains shall be staggered around the circumference of the main such that no two lie in the same plane.
5. All taps shall be properly bedded.

**E. Taps on Existing Mains**

1. All service taps or main taps on existing mains will be made by Missoula Water personnel.
2. Missoula Water personnel will provide and install the corporation stop and saddle for service taps 2 inches and smaller.
3. Missoula Water personnel will provide the sleeve but not the valve for service taps larger than 2 inches.
4. The contractor must apply for and schedule taps a minimum of 72 hours in advance. Taps on steel and AC mains require a minimum 1-week notice in order to schedule an asbestos abatement contractor.
5. Two-week minimum notice will be required for taps 2 inches and larger to allow for shipping of tapping sleeves.
6. It shall be the contractor’s responsibility to connect the service line to the corporation stop as required, install the service line, curb valve and box, meter pit and turn on corporation.

7. Curb box, stop and service line to main must be in place and exposed prior to Missoula Water installing the tap.
8. Trace wire as defined in [City of Missoula Modification to MPWSS Section 02221](#) shall be attached to the corporation stop or to a stripped portion of the tracer wire on the main.
9. Taps on new and replacement mains shall be made by and the materials provided by the contractor.
10. Contractor shall thoroughly flush service lines and take all other necessary precautions to eliminate all filings and other debris resulting from the tapping procedure.

#### **4.3.8 Water Service Lines**

##### **A. Products**

1. Service lines smaller than 4 inches shall be Polyethylene (PE) water service pipe. Polyethylene pipe shall be manufactured in accordance with AWWA C901-17 for sizes 1-1/4-inch thru 3-inch IPS diameters and to the requirements of ASTM D3035, and 2-inch and smaller water service pipe and tubing shall be manufactured in accordance with ASTM D2239 for inside diameter control IPS size.
2. Black PE materials used for the manufacture of polyethylene pipe, tube and fittings shall be PE 4710 high density polyethylene resin meeting ASTM D3350 cell classification 445574C, and shall be listed in the name of the pipe and fitting Manufacturer in PPI (Plastics Pipe Institute) TR-4 with a standard grade HDB rating of 1600 psi at 73°F. The material shall be listed and approved for potable water in accordance with NSF/ANSI 61.
3. The Dimension Ratio (DR), using Inside Diameter (ID) base dimensions shall be 7.
4. The AWWA Pressure Class (PC) shall be 250 psi. Inspection, testing and marking of the PE shall be as specified in AWWA C901.
5. Ductile iron pipe meeting the requirements of Section 4.3.1 of this chapter may be used for service lines and fire lines 4 inches in diameter or greater. C900 PVC pipe may also be used for service lines, including fire lines, up to a point 5 feet from the building. All service lines and fire lines 4 inches and larger shall be properly restrained inside the building using threaded rod and/or engineered restraint devices.
6. Service line fittings may be connected with Mueller Pack Joint or compression-type couplers or approved equal. Mueller INSTA-TITE fittings are not allowed.
7. Tracer wire shall be installed in all water main and service line trenches. Tracer wire shall be at a minimum #14 solid copper direct bury wire and shall be blue color

##### **B. Installation**

1. Tracer wire as defined in [City of Missoula Modification to MPWSS Section 02221](#) shall be installed with all service lines. Tracer wire must maintain continuity from main to inside of building. Leave 10 feet minimum of wire in building for connection to plumbing.
2. Buried water line warning tape as defined in [City of Missoula Modification to MPWSS Section 02221](#) shall be installed with all service lines.
3. When indoor plumbing is plastic, tracer wire shall be connected directly to metal pipe leading to an outside hose bib to facilitate service line location from outside the building.

4. Water service lines should be pressure tested to the curb box concurrently with the water main.
5. Service lines encountered during construction activities shall be repaired in accordance with the Service Line Repair Standards found in Section 4.2.14 of this chapter.
6. Service lines should be installed at least 10-ft laterally from any existing tree.

#### **4.3.9 Curb Stops**

##### **A. Products**

1. Curb stop shall be Mueller 300 Series Ball Valve, Ford B Series, or approved equal.
2. Curb box shall be extension type, stationary rod, Minneapolis pattern, 1-1/2 inch diameter and shall be Mueller H-10302 or approved equal. Curb box lids must have cast iron plugs. No plastic or brass plugs will be allowed.

##### **B. Installation**

1. Curb stops and boxes shall be located 2 feet outside the property line as shown on the project plans.
2. The box shall be final set so the top of the box is at finished ground elevation.
3. In areas of new construction, each box shall be marked with a blue painted 2-inch × 4-inch board 4 feet long set vertically in the ground to extend 2 feet above the ground or with a blue painted metal fence post.
4. Trace wire as defined in [City of Missoula Modification to MPWSS Section 02221](#) shall be looped loosely over the curb box.
5. Curb stops must be operable. Contractor is responsible for all costs, including damages due to improperly installed curb boxes.

#### **4.3.10 Meter Pits**

##### **A. Products**

1. Meter pits for meters 1-inch and smaller shall be Mueller Thermacoil, Ford Pitsettter, or AY McDonald Coil Type Pitsettter as shown in [City of Missoula Standard Drawing 412](#).
2. Meter pits for irrigation meters larger than 1-inch can be installed in concrete pits as shown in [City of Missoula Standard Drawing 413](#).

##### **B. Installation**

1. Meter pits must be installed within 2 to 5 feet of the right of way line as shown in [City of Missoula Standard Drawing 412](#).
2. A minimum 4-foot radius clear area around the meter pit must be maintained to allow access by Missoula Water personnel for maintenance of the meter.
3. Meter pits must not be buried nor access obstructed by fences or landscaping materials.
4. Plastic meter pits shall not be installed in areas with vehicle traffic nor in permanent walkways such as sidewalks.
5. For irrigation meters installed in concrete pits, a ½-inch conduit must be run from the meter to the outside of an exterior wall for installation of a remote transmitter.

#### 4.3.11 Cross-Connection/Backflow

Missoula Water's complete Cross-Connection/Backflow program can be found in [Appendix 4-A](#).

#### 4.3.12 Disinfection and Bacteriological Testing

##### A. Overview

1. This standard presents essential procedures for disinfecting new and repaired water infrastructure. All new water mains, wells, tanks and equipment that can convey or store potable water, shall be disinfected before they are placed in service. New mains must also be disinfected and tested for bacteria prior to pressure testing.
2. All water mains taken out of service for inspecting, repairing, or other activity which might lead to contamination of water shall be disinfected before they are returned to service.
3. Disinfection of water mains shall be in accordance with the guidelines set forth in this section and with AWWA C651.

**B. Forms of Chlorine.** The forms of chlorine that may be used in the disinfection operations are sodium hypochlorite solution and calcium hypochlorite granules or tablets.

1. **Sodium Hypochlorite.** Sodium hypochlorite is available in liquid form in glass, rubber-lined, or plastic containers of 5 gallons. Larger sizes may be available in some areas. Sodium hypochlorite contains approximately 5% to 15% available chlorine, but care must be used in control of conditions and length of storage to minimize its deterioration. (Note: Available chlorine is expressed as a percent of weight when the concentration is 5% or less and usually as a percent of volume for higher concentrations. Percent x 10 = grams of available chlorine per liter of hypochlorite.)
2. **Calcium Hypochlorite.** Calcium hypochlorite is available in granular form and contains approximately 65% available chlorine by weight. Calcium hypochlorite tablets are not allowed to be used. The materials should be stored in a cool, dry, and dark environment to minimize its deterioration. Calcium hypochlorite should not come into contact with any oily substances as this could lead to spontaneous combustion.

**C. Basic Disinfection Procedure.** The basic disinfection procedure consists of:

1. Preventing contaminating materials from entering the water main during storage, construction, or repair.
2. Removing by flushing or other means those materials that may have entered the water main.
3. Chlorinating any residual contamination that may remain and flushing the chlorinated water from the main.
4. Determining the bacteriological quality by a certified laboratory test after disinfection.

##### B. Preventive and Corrective Measures During Construction

Heavy particulates may contain bacteria and will prevent very high concentrations of chlorine from contacting and killing such organisms. It is therefore essential that the procedures of this section be observed to assure that a water main and its appurtenances are thoroughly clean for the final disinfection by chlorination.



### **C. Keeping Pipe Clean and Dry**

1. Precautions shall be taken to protect the interiors of pipes, fittings, and valves against contamination.
2. Pipe delivered for construction shall be laid out so as to minimize entrance of foreign material.
3. All openings in the pipeline shall be closed with watertight plugs when pipe laying is stopped at the close of the day's work or for other reasons such as rest breaks or meal periods.
4. Rodent-proof plugs may be used where it is determined that watertight plugs are not practicable and where thorough cleaning will be performed by flushing or other means.
5. Delay in placement of delivered pipe invites contamination.
6. The more closely the rate of delivery is correlated to the rate of pipe laying, the less likelihood of contamination.

### **D. Gaskets**

1. All gaskets and lubricants shall meet NSF Standard 61 for water contact materials.
2. Gaskets shall be handled in a manner which avoids contamination.
3. The lubricant used in the installation of sealing gaskets shall be suitable for use in potable water.
4. It shall be delivered to the job in closed containers and shall be kept clean.

### **E. Cleaning and Swabbing**

If dirt enters the pipe that, in the opinion of the City Utility Engineer or inspector will not be removed by the flushing operation, the interior of the pipe shall be cleaned by mechanical means and then shall be swabbed with a 1% hypochlorite disinfecting solution.

### **F. Wet-Trench Construction**

1. If it is not possible to keep the pipe and fittings dry during installation, every effort shall be made to assure that any of the water that may enter the pipe joint spaces contains an available chlorine concentration of approximately 25 mg/L.
2. This may be accomplished by adding calcium hypochlorite granules or tablets to each length of pipe before it is lowered into a wet trench or by treating the trench with hypochlorite tablets.

### **G. Flooding by Storm, Accident, or Other Cause during Construction**

1. If the main is flooded during construction, it shall be cleared of the flood water by draining and by flushing with potable water until clean.
2. The section exposed to the flood water shall then be filled with chlorinated potable water which at the end of the 24-hour holding period will have a free chlorine residual of not less than 25 mg/L.
3. The chlorinated water may then be drained or flushed from the main.

### **H. Methods of Chlorination.**

1. Granules Method
  - a. The granules method gives an average chlorine dose of approximately 25 mg/L

- b. The granules method consists of placing calcium hypochlorite granules in the water main as it is being installed and then filling the main with potable water when installation is completed.
- c. The granules used must be approved for potable water use.
- d. This method may be used only if the pipes and appurtenances are kept clean and dry during construction.
- e. During construction, granules shall be placed at the upstream end of the first section of pipe, at the upstream end of each branch main, and at 500 foot intervals.
- f. The quantity of granules shall be as shown in Table 4-3 shall be placed at the beginning of the main and at each 500-foot interval.

**Table 4-3 - Quantity of Calcium Hypochlorite Required for Disinfection**

Pipe Diameter (inches)	Calcium Hypochlorite Granules (ounces)
4	0.5
6	1.0
8	2.0
12	4.0
16 and larger	8.0

- g. When installation has been completed, the main shall be filled with water at a rate such that water within the main will flow at a velocity no greater than 1 fps.
  - h. Precautions shall be taken to assure that air pockets are eliminated.
  - i. This water shall remain in the pipe for at least 24 hours.
  - j. If the water temperature is less than 5°C (41°F) the water shall remain in the pipe for at least 48 hours.
  - k. Valves shall be positioned so that the strong chlorine solution in the main being treated will not flow into water mains in active service.
- 2. Continuous Feed Method**
- a. The continuous feed method gives a 24-hour chlorine residual of not less than 10 mg/L.
  - b. The continuous feed method consists of placing calcium hypochlorite granules in the main during construction (optional), completely flushing the main to remove particulates, and filling the main with potable water chlorinated so that after a 24-hour holding period in the main there will be a free chlorine residual of not less than 10 mg/L.
  - c. At the option of the engineer of record, calcium hypochlorite granules shall be placed in pipe sections. The purpose of this procedure is to provide a strong chlorine concentration in the first flow of flushing water that flows down the main. This procedure is recommended particularly where the type of pipe is such that this first flow of water will flow into annular spaces at pipe joints.

- d. Prior to being chlorinated, the main shall be filled to eliminate air pockets and shall be flushed to remove particulates. The flushing velocity in the main shall be not less than 2.5 fps unless City Utility Engineer or inspector determines that conditions do not permit the required flow to be discharged to waste. Table 4-4 shows the rates of flow required to produce a velocity of 2.5 fps in pipes of various sizes. Note: Flushing is not a substitute for preventive measures during construction. Certain contaminants such as caked deposits resist flushing at any feasible velocity.
- e. In mains of 24 inches or larger diameter, an acceptable alternative to flushing is to broom sweep the main, carefully removing all sweepings prior to chlorinating the main.

**Table 4-4 – Required Flow and Openings to Flush Pipelines with 40 PSI Residual in Main<sup>(a)</sup>**

Pipe Diameter (inches)	Flow required to produce 2.5 fps velocity (gpm)	Size of tap on main <sup>(b)</sup> (inches)	Hydrant Outlets	
			Number	Size (inches)
4	100	15/16	1	2 ½
6	220	1 3/8	1	2 ½
8	390	1 7/8	1	2 ½
10	610	2 5/16	1	2 ½
12	880	2 13/16	1	2 ½
16	1565	3 5/8	2	2 ½
20	2450	-	-	-

(a) With 40 psi pressure in the main with the hydrant flowing to atmosphere, a 2-1/2 inches hydrant outlet will discharge approximately 1000 gpm and a 4-1/2-inch hydrant nozzle will discharge approximately 2500 gpm.

(b) Size of tap on main with no significant length of discharge piping

- f. Water from the existing distribution system shall be made to flow at a constant measured rate into the newly laid water main. In the absence of a meter, the rate may be approximated by methods such as placing a pitot gauge in the discharge, measuring the time to fill a container of known volume or measure the trajectory of the discharge and using the formula shown in Figure 4-1.

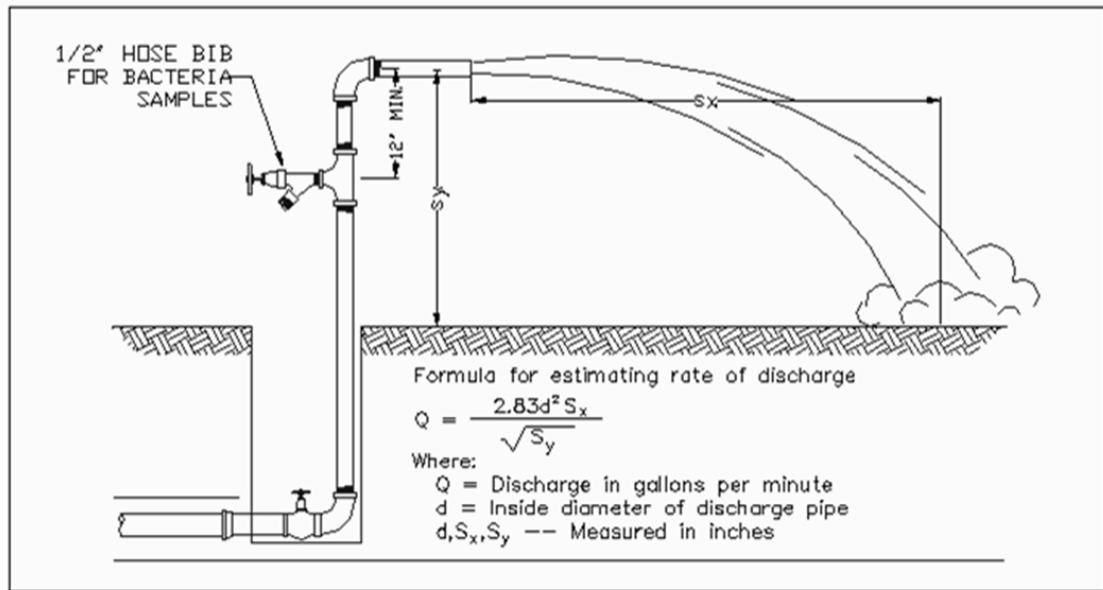

**Figure 4-1 – Suggested Combination Blow-off and Sampling Tap**

- g. At a point not more than 10 feet downstream from the beginning of the new main, water entering the new main shall receive a dose of chlorine fed at a constant rate such that the water will have not less than 25 mg/L chlorine concentration. To assure that this concentration is provided, the chlorine concentration should be measured at regular intervals in accordance with the procedures described in the current edition of Standard Methods of AWWA M12-Simplified Procedures for Water Examination or using appropriate test kits.
- h. Table 4-5 gives the amount of chlorine required for each 100 feet of pipe of various diameters. Solutions of 1% chlorine may be prepared with sodium hypochlorite or calcium hypochlorite. The latter solution requires 1 pound of calcium hypochlorite in 8 gallons of water.

**Table 4-5 - Chlorine at 1% Concentration Required to Produce 25 mg/L Concentration**

Pipe Diameter (in)	1% Chlorine Solution (gal)
4	.16
6	.36
8	.65
10	1.02
12	1.44
16	2.60
20	3.57

- i. During the application of chlorine, valves shall be positioned so that the strong chlorine solution in the main being treated will not flow into water mains in active service. Chlorine application shall not cease until the entire main is filled with heavily chlorinated water. The chlorinated water shall be retained in the main for at least 24 hours, during which time all valves and hydrants in the section treated shall be operated in order to disinfect the appurtenances. At the end of the 24-hour period, the treated water in all portions of the main shall have a residual of not less than 10 mg/L free chlorine.

### 3. Slug Method

- a. The slug method gives a 3-hour exposure of not less than 50 mg/L free chlorine.
- b. The slug method consists of placing calcium hypochlorite granules in the main during construction, completely filling the main to eliminate all air pockets, flushing the main to remove particulates, and slowly flowing through the main a slug of water dosed with chlorine to a concentration of 100 mg/L, in order that all parts of the main and its appurtenances will be exposed to the highly chlorinated water for a period not less than 3 hours.
- c. Placing of calcium hypochlorite granules, preliminary flushing, and chlorinating the main shall be done in accordance with the procedures outlined in the Continuous Feed Method.
- d. At a point not more than 10 feet downstream from the beginning of the new main, water entering the new main shall receive a dose of chlorine fed at a constant rate such that the water will have not less than 100 mg/L free chlorine. To assure that this concentration is provided, the chlorine concentration should be measured at regular intervals. The chlorine shall be applied continuously and for a sufficient period to develop a solid column or "slug" of chlorinated water that will, as it moves through the main, expose all interior surfaces to a concentration of approximately 100 mg/L for at least 3 hours.
- e. The free chlorine residual shall be measured in the slug as it moves through the main. If at any time it drops below 50 mg/L the flow shall be stopped, chlorination equipment shall be relocated at the head of the slug and as flow is resumed, chlorine shall be applied to restore the free chlorine in the slug to not less than 100 mg/L.
- f. As the chlorinated water flows past fittings and valves, related valves and hydrants shall be operated so as to disinfect appurtenances and pipe branches.

#### I. Final Flushing

After the applicable contact time period, the heavily chlorinated water shall be flushed from the main until chlorine measurements show that the concentration in the water leaving the main is no higher than that generally prevailing in the system. All chlorinated water being discharged to surface waters or active irrigation ditches shall be dechlorinated in accordance with Section I.

Dechlorination.

## **J. Dechlorination**

1. Discharge of chlorinated water shall be performed in accordance with the Missoula Valley Water Quality District's Policy Statement on "Allowable non-stormwater discharges" contained in [Appendix 4-C](#).
2. Any chlorinated water discharged to dry wells does not require dechlorination.
3. Planned discharges to conveyances connected to surface waters must be dechlorinated to below 0.01 ppm.
4. Analytical results showing concentrations less than or equal to 0.1 ppm total residual chlorine (TRC) are considered to be in compliance.
5. Missoula Water staff shall assist with dechlorination where required.
6. Discharges to surface water (including irrigation ditches) must be coordinated with the irrigation ditch owner and the MDEQ. Discharge to surface water may not exceed surface water standards established in Circular DEQ-7 and may require a permit.

## **K. Bacteriological Tests**

1. Standard Conditions
  - a. After final flushing and confirmation that the chlorine residual is 0.5 ppm or less, and before the water main is placed in service, bacteriological tests must be performed to certify the water sampled from the main to be free of coliform bacteria contamination.
  - b. Two consecutive samples collected 24 hours apart shall be required from the new main and each branch thereof. In the case of extremely long mains, it is desirable that samples be collected along the length of the line as well as at its end.
  - c. Each sample will be collected by both the engineer of record for processing at a certified lab and Missoula Water personnel for processing at the Missoula Water lab.
  - d. Prior to proceeding with a pressure test, it must be determined that all samples are free of bacterial contamination. Samples processed by a certified lab must be free of bacterial contamination in accordance with the requirements of the specific tests performed. For tests performed in the Missoula Water lab, the first sample must be free of bacterial contamination for a period of 48 hours and the second sample must be free of bacterial contamination for a period of 24 hours. A standard plate count may be required at the option of the engineer of record.
2. Special Conditions
  - a. If, during construction, trench water has entered the main, or if in the opinion of City Utility Engineer or inspector, excessive quantities of dirt or debris have entered the main, bacteriological samples shall be taken at intervals of approximately 200 feet and shall be identified as to location.
  - b. Samples shall be taken of water that has stood in the main for at least 16 hours after flushing has been completed.
3. Sampling Procedures

- a. Samples for bacteriological analysis shall be collected in sterile bottles treated with sodium thiosulfate.
  - b. No hose or fire hydrant shall be used in collection of samples unless specifically approved. A suggested combination blow off and sampling tap useful for main up to and including 8-inch diameter is shown in Figure 4-1 of this chapter. A corporation cock may be installed in the main for sampling use.
- 4. Redisinfection**
- a. If the initial disinfection fails to produce satisfactory bacteriological samples, the main shall be reflashed and shall be resampled. If check samples show the presence of coliform organisms, then the main shall be rechlorinated by the continuous feed or slug method of chlorination until satisfactory results are obtained.
  - b. High velocities in the existing system, resulting from flushing the new main may disturb sediment that has accumulated in the existing mains. When check samples are taken, it is recommended to sample water entering the new main.
- 5. Disinfection Procedures When Cutting into or Repairing Existing Mains**
- a. The following procedures apply primarily when mains are wholly or partially dewatered.
  - b. After the appropriate procedures have been completed, the main may be returned to service prior to completion of bacteriological testing in order to minimize the time customers are out of water.
  - c. Leaks or breaks that are repaired with clamping devices while the mains remain full of water under pressure present little danger of contamination and require no disinfection.
- 6. Swabbing with Hypochlorite Solution**
- The interior of all pipe and fittings used in making the repair (particularly couplings and sleeves) shall be swabbed or sprayed with a 1% hypochlorite solution before they are installed.
- 7. Flushing**
- a. Thorough flushing is the most practical means of removing contamination introduced during repairs. If valve and hydrant location permit, flushing toward the work location from both directions is recommended.
  - b. Flushing shall be started as soon as the repairs are completed and shall be continued until discolored water is eliminated.
- 8. Slug Chlorination**
- a. Where practical in addition to the procedures above, a section of main in which the break is located shall be isolated, all service connections shut off, and the section flushed and chlorinated, except that the dose may be increased to as much as 300 mg/L and the contact time reduced to as little as 15 minutes.
  - b. After chlorination, flushing shall be resumed and continued until discolored water is eliminated and the water is free of noticeable chlorine odor.
- 9. Sampling**

- a. Bacteriological samples shall be taken after repairs to provide a record by which the effectiveness of the procedures used can be determined.
- b. If the direction of flow is unknown, samples shall be taken each side of the main break.
- c. If positive samples are recorded, daily sampling shall be continued until two consecutive negative samples are recorded.
- d. Positive samples shall be evaluated by the engineer of record for corrective action.