











-  TYPE III BARRICADE
-  TYPE II BARRICADE
-  TYPE I BARRICADES

-  WARNING SIGNS
-  DETOUR SIGNS
-  DETOUR ROUTING
-  REGULATORY SIGNS

-  DELINEATORS
-  SIGN LOCATION SYMBOL
-  WORK ZONE

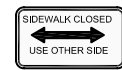

SIDEWALK CLOSED  
MUST BE USED  
WHENEVER A CITY  
SIDEWALK IS TO BE  
CLOSED

TRAFFIC CONTROL MUST CONFORM TO THE MANUAL ON UNIFORM TRAFFIC CONTROL DEVICES (MUTCO)

ADVANCED WARNING  
REQUIRED ON CROSS  
STREETS IF THEY ARE  
COLLECTORS OR ARTERIALS

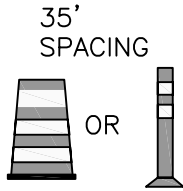

35'  
SPACING  
OR  
CLOSE TWO DRIVING LANES  
MAINTAIN 2 WAY TRAFFIC  
(2) 10' MINIMUM LANES

SPACING AND TAPER LENGTHS  
CALCULATED FOR 35 MPH  
HIGHER SPEEDS MAY REQUIRE  
CHANGED DISTANCES AND  
ADDITIONAL SIGNING

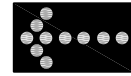
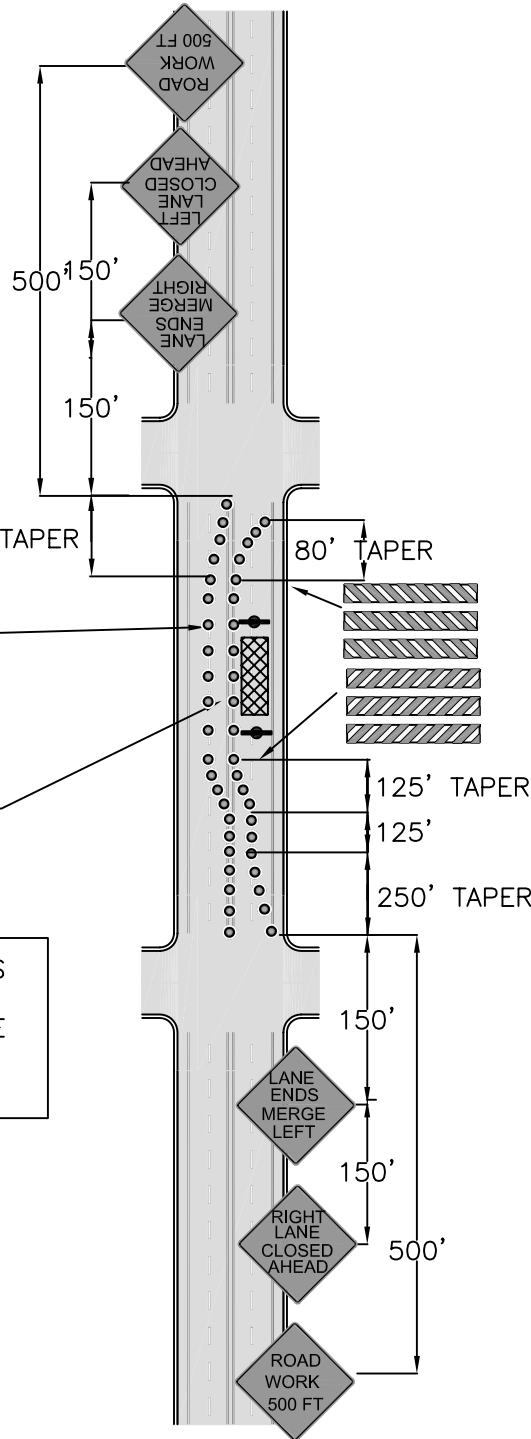

MAY BE  
REQUIRED  
FOR HIGHER  
VOLUMES OR  
SPEEDS

Digital Standard Drawings and other maps are available on the City website: [http://www.ci.missoula.mt.us/publicworks/gis\\_maps.htm](http://www.ci.missoula.mt.us/publicworks/gis_maps.htm)

# TYPICAL TRAFFIC CONTROL PLAN

STREET CLASSIFICATION:

4 LANE ARTERIAL

CLOSE TWO DRIVING LANES MAINTAIN 2-WAY TRAFFIC

Revision Date:

03/2004

TC - 403

