

D&L 3558/EJIW 7222
OR APPROVED EQUIVALENT

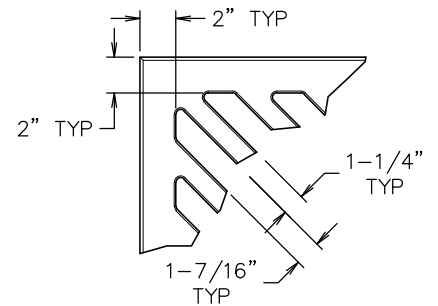

GRATE OPENING
DETAIL

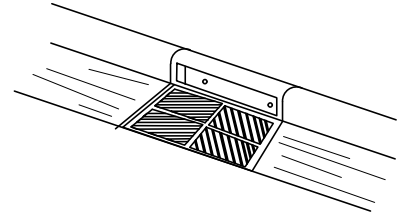
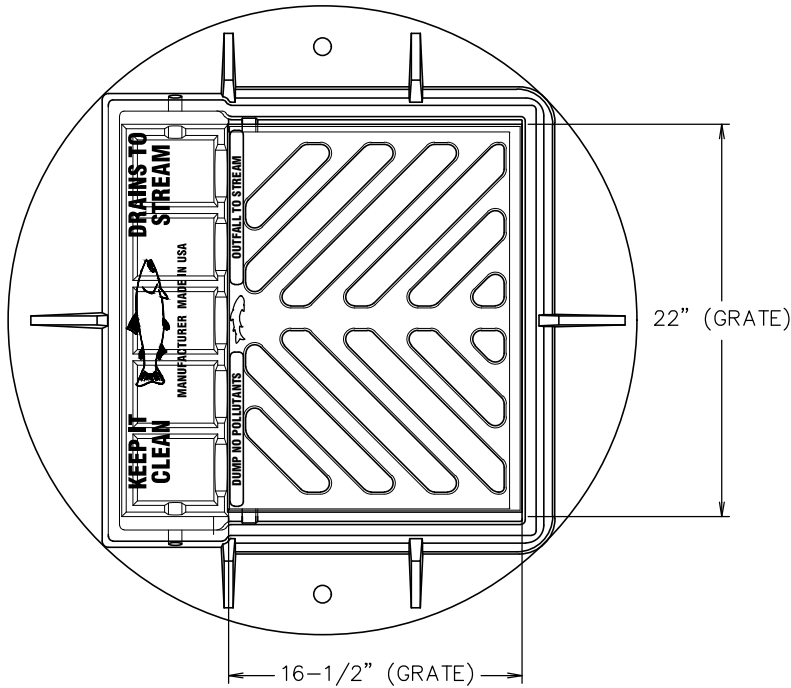
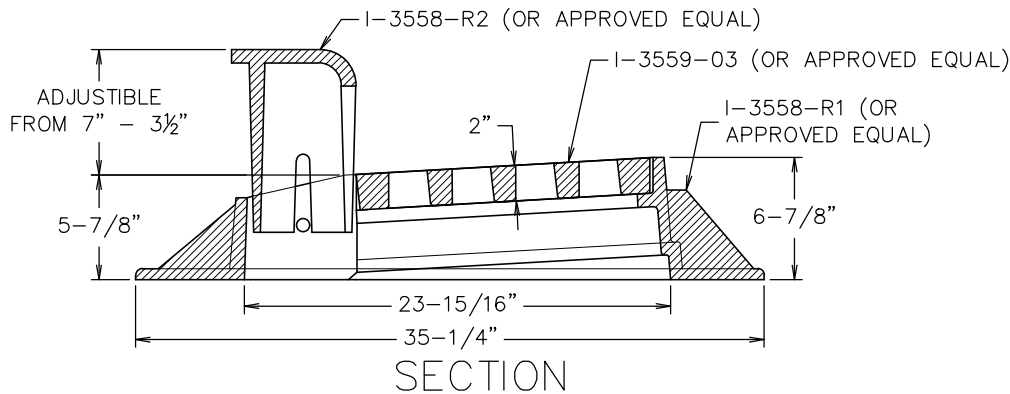

SECTION

GENERAL NOTES:

1. CONSTRUCTION MATERIALS AND PROCEDURES SHALL COMPLY WITH MONTANA PUBLIC WORKS STANDARD SPECIFICATIONS (MPWSS), 7TH EDITION, APRIL 2021, AS MODIFIED BY THE MISSOULA CITY PUBLIC WORKS STANDARDS AND SPECIFICATIONS MANUAL, APPENDIX 2-A (STANDARD MODIFICATIONS TO MPWSS), CURRENT EDITION.
2. COMBINATION CURB INLET FRAME AND GRATE SHALL BE USED WHERE INLET OR DRY WELL IS LOCATED IN TYPICAL "L" TYPE CURB & GUTTER (STD-740).
3. DUE TO PROVISIONS IN THE INTERMODAL SURFACE TRANSPORTATION ACT, VENDORS MUST AUTHENTICATE U.S. ORIGIN OF CASTINGS FOR FEDERALLY FUNDED PROJECTS.
4. VANED GRATE (D&L I-3559-04 OR APPROVED EQUAL) SHALL BE USED WHEN SLOPE EXCEEDS 5%.
5. PROVIDE LIDS AND RINGS THAT MEET AASHTO 306 H2O LOADING RATING OR HIGHER.
6. COMPOSITE TAPERED GRADE RINGS SHALL BE USED TO MATCH FRAME & GRATE TO THE RUNNING SLOPE OF THE CURB.
7. GRATE SHALL MATCH RUNNING SLOPE OF STREET.
8. GROUT BOLT SLOTS LOCATED IN THE CURB LINE AND ALL OTHER OPENINGS TO BASE COURSE AND BACKFILL MATERIAL.



Engineering Division

24" COMBINATION CURB INLET FRAME & GRATE

A. Schultz

Approved By
Utility Engineer
Andy Schultz, PE

Adopted: 09/28/2020
Revised: 01/01/2023

STD - 601